



REGISTERED FIRM
ISO 9001
JISZ 9901



LR104996

Instruction Manual

Our products are produced
as per international quality
system standards ISO9001.

Our products have got CSA
approval (Canadian standards
association).

Oil-free Scroll Vacuum Pump

ISP-250B

ISP-500B

This instruction manual includes important warnings, cautions, and instructions for safe and effective use of the scroll vacuum pump. Be sure to read this manual thoroughly and understand it fully before use. Retain it carefully for easy reference.

※ Before use, be sure to fill in the below chart for future repair and servicing.

Serial No.
Dealer
Purchase date
When you began operation

Anest Iwata Corporation, Yokohama, Japan. June, 1999



Important information

Be sure to read this manual to understand operation and functions correctly. Only operators, who fully understand warnings, cautions and instructions, are to operate the equipment. If not, fire, explosion, serious bodily injury or death may occur.



◆ About safety

Warnings and cautions are especially important for safe operation. Symbols and marks have the following meanings.

Examples of symbols

 WARNING	Indicates a potentially hazardous situation which, if not avoided, may result in serious injury or loss of life.
 CAUTION	Indicates a potentially hazardous situation which, if not avoided, may result in minor or moderate injury or property damage.

Examples of symbols

	Indicates [you must be careful]. We will explain briefly in or near the symbol. (The example on the left is [Be careful about electric shock])
	Indicates [you must not do]. We will explain briefly in or near the symbol. (The example on the left is [Never touch])
	Indicates [you must do]. We will explain briefly in or near the symbol. (The example on the left is [Be sure to ground])

* We shall not be responsible for any injury or damage caused by disregard of warnings, cautions or instructions.

Supplementary notes













	Indicates notes which we ask you to observe. They are helpful to achieve full performance and function of the equipment.
---	--

Contents

Important information.	1
Contents.	2
1. For safe operation.	3
2. Specifications.	6
3. Names of each section.	8
4. Outer dimensions.	10
5. Installation.	12
6. Operation.	17
7. Maintenance and inspection.	21
8. Problems and remedies.	23

1. For safe operation

As the below points are very important for safe operation, be sure to read and fully understand the contents before operation.

 WARNING			
 Pump clean gas	Never pump toxic, explosive, flammable, corrosive gases, chemicals, solvents or powders. ※Flowing substances, explosion or fire can cause bodily injury.		
 Install at a safe site	Install in an area without explosive, flammable substances. ※ If not, it can cause explosion or fire.	 Avoid moisture	Install in an area which is not exposed to moisture such as rain or steam. ※ If not, it can cause electric shock.
 Cut off electric source	Be sure to cut off electric source before wiring or inspection. ※If not, it can cause electric shock or damage by turning section(fan).	 Ask qualified electrician	Ask qualified electrician to perform electric wiring job. ※If not, electric shock may occur.
 Do not touch	Never put fingers or foreign matter into air hole of pump or clearance of cooling fins. ※ If done, it can cause injury.	 Do not alter	Never alter the equipment. ※ If done, it can cause damage or shorter lifetime.
 Be sure to ground	Be sure to ground. ※ If not, it can cause electric shock or fire.	 Install breaker	Prevent short-circuit with ground leakage breaker of proper capacity. ※ If not, it can cause electric shock or fire.
 Ask specialist to perform repairs	Ask specialist to perform repairs. ※ If not, it can cause failure, damage or shorter lifetime.	 Install emergency stop switch	Be sure to install electric source switch. ※ If not, it can cause damage or fire.



CAUTION



Install in a safe place

Install in a safe place.

○ Install on a level foundation (an inclination of less than 5°).

○ In a place free of dirt or dust from iron, stone or wood.

○ In a place free of corrosive gas.

※ If done, it can cause damage, decrease in performance or shorter lifetime.



Use at designated temperature

Use at temperature of 5 ~ 40°C (during operation).

※ If not, it can cause damage or shorter lifetime.



Conduct periodic maintenance

Conduct periodic maintenance and inspections.

※ If not, it can cause damage or shorter lifetime.



Maintenance after pump is cool

Do the maintenance after pump becomes fully cool.

※ If not, it can cause burns.



Start or stop after closing isolation valve

Be sure to close isolation valve between pump and vacuum system (chamber) during startup and stop.

※ If not, debris attached to inside of pump can be drawn back to vacuum chamber.

Where to attach warning stickers

Where to attach warning stickers

Always keep warning stickers clean. If they become dirty or lost, replace them with new ones. If you need stickers, contact the shop which sold the vacuum pump to you.

ISP-250B single phase

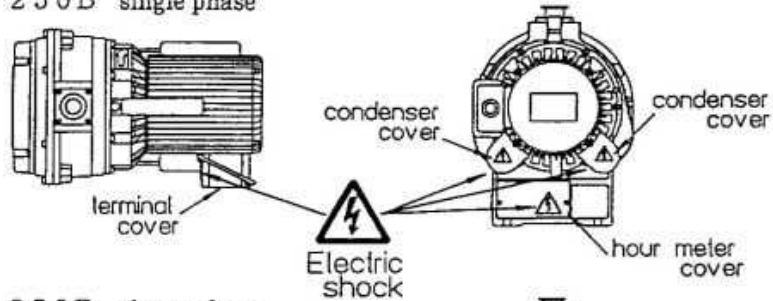

ISP-250B three phase

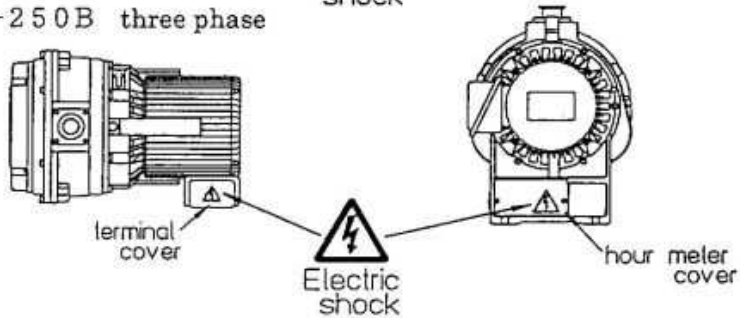

ISP-500B single phase

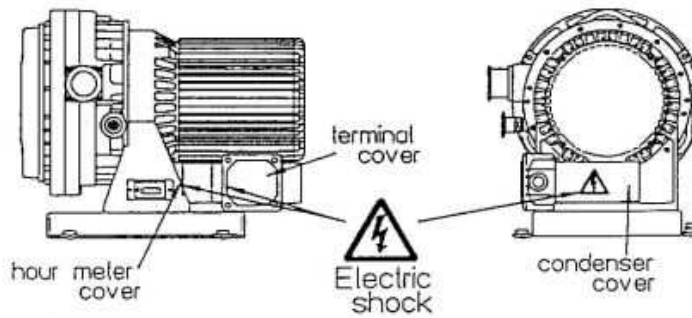

ISP-500B three phase

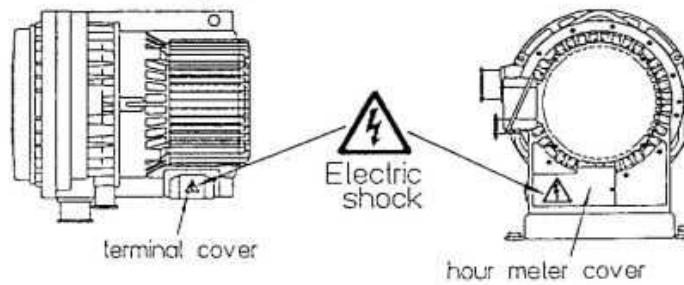

2. Specifications

2. 1 ISP-250B

Model		ISP-250B										
Displacement (swept volume) L/min	50H	250										
	60H	300										
Ultimate pressure Pa(Torr)		≤ 1.6 ($\leq 1.2 \times 10^{-2}$)										
Leak tightness Pa(mbar) · L/S		$\leq 1.0 \times 10^{-2}$ ($\leq 1.0 \times 10^{-4}$)										
Max. intake pressure		Atmospheric pressure										
Ambient operating temperature range		5°C~40°C										
Motor	Type	Single-phase induction motor totally-enclosed ·4P·B class insulation, capacitor start (without external overheat protection)					3-phase induction motor totally enclosed ·4P·B class insulation (without external overheat protection)					
	Output kW	0.4										
	Voltage V	100	115	200	230	200	208	230	380	415	460	
	Rated current A	50H	4.2	—	2.0	2.2	1.6	—	—	0.9	1.0	—
		60H	4.3	3.8	2.2	1.9	1.9	1.9	1.8	—	—	1.0
	Revolution min ⁻¹ (rpm)	50H	1430	—	1420	1440	1420	—	—	1440	1450	—
60H		1720	1740	1710	1730	1670	1680	1710	—	—	1720	
Noise level 1m dB(A) with air flush ON(opened)		≤ 58 ≤ 66										
Inlet connection		NW25										
Outlet connection		NW16										
Direction of inlet		Perpendicularly fitted										
Dimensions mm L×W×H		400×252×336					370×252×336					
Mass kg		25					23					
Cooling system		Air-cooled										
Others		With hour meter and air flush										

Note 1 : Pumping speed and ultimate pressure remain roughly the same when air flush is ON(opened) and OFF (closed).

Note 2 : Noise level is measured at ultimate pressure in an anechoic room.

Note 3 : Leak tightness is measured when pump is stopped and air flush is OFF (closed).

Note 4 : Water vapor handling is less than 25g/day when air flush is ON (opened).
Air flush volume is 10 liters/min.

Note 5 : Air flush is OFF (closed) when pump is delivered.

2. 2 ISP-500B

Model		ISP-500B										
Displacement (swept volume) L/min	50H	500										
	60H	600										
Ultimate pressure Pa(Torr)		≤ 1					$(\leq 7.5 \times 10^{-3})$					
Leak tightness Pa(mbar) · L/S		$\leq 1.0 \times 10^{-2}$					$(\leq 1.0 \times 10^{-4})$					
Max. intake pressure		Atmospheric pressure										
Ambient operating temperature range		5°C ~ 40°C										
Motor	Type	Single-phase induction motor Totally-enclosed · 4P · B class insulation capacitor start(without external overheat protection)					3-phase induction motor totally-enclosed · 4P · B class insulation (without external overheat protection)					
	Output kW	0.6										
	Voltage V	100	115	200	230	200	208	230	380	415	460	
	Rated current A	50H	8.5	—	4.3	3.9	2.7	—	—	1.57	1.63	—
		60H	10.0	8.6	4.8	4.0	2.8	2.6	2.5	—	—	1.47
	Revolution min ⁻¹ (rpm)	50H	1430	—	1430	1450	1460	—	—	1470	1470	—
60H		1660	1720	1690	1730	1740	1740	1760	—	—	1770	
Noise level 1m dB(A) with air flush ON(opened)		≤ 62 ≤ 70					≤ 60 ≤ 68					
Inlet connection		NW40										
Outlet connection		NW25										
Direction of inlet		Laterally fitted					(perpendicularly fitted)					
Dimensions mm L×W×H		443×328×372 (443×298×397)					372×328×372 (372×298×397)					
Mass kg		44					38					
Cooling system		Air-cooled										
Others		With hour meter and air flush										

Note 1 : Pumping speed and ultimate pressure remain roughly the same when air flush is ON(opened) and OFF (closed).

Note 2 : Noise level is measured at ultimate pressure in an anechoic room.

Note 3 : Leak tightness is measured when pump is stopped and air flush is OFF (closed).

Note 4 : Water vapor handling is less than 25g/day when air flush is ON (opened).
Air flush volume is 10 liters/min.

Note 5 : Air flush is OFF (closed) when pump is delivered.

2. 3 Performance data

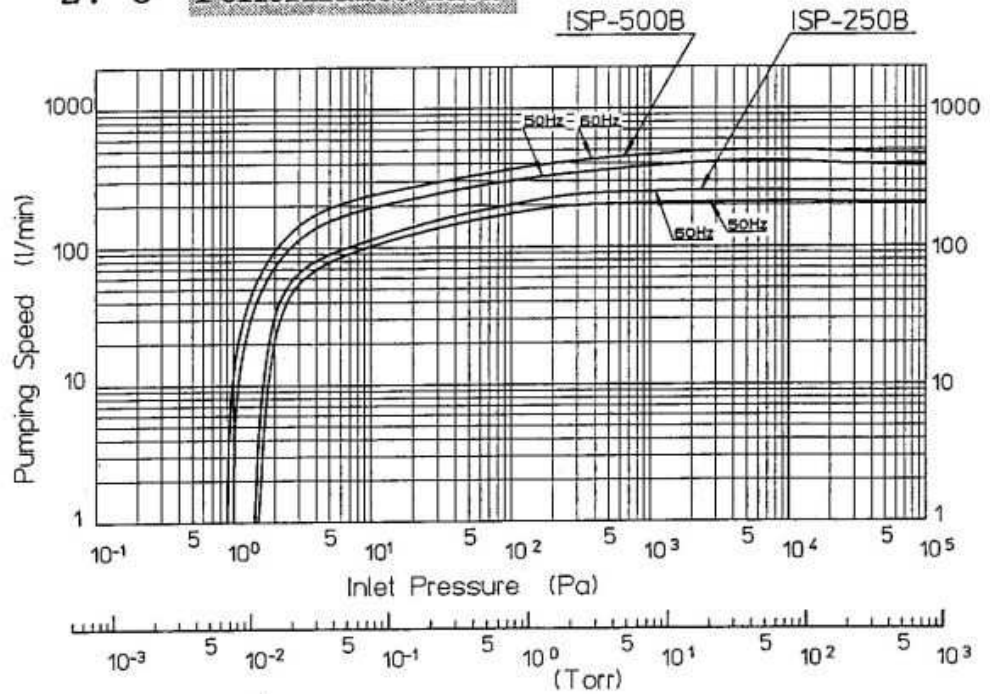

3. Names of each section

3. 1 Construction

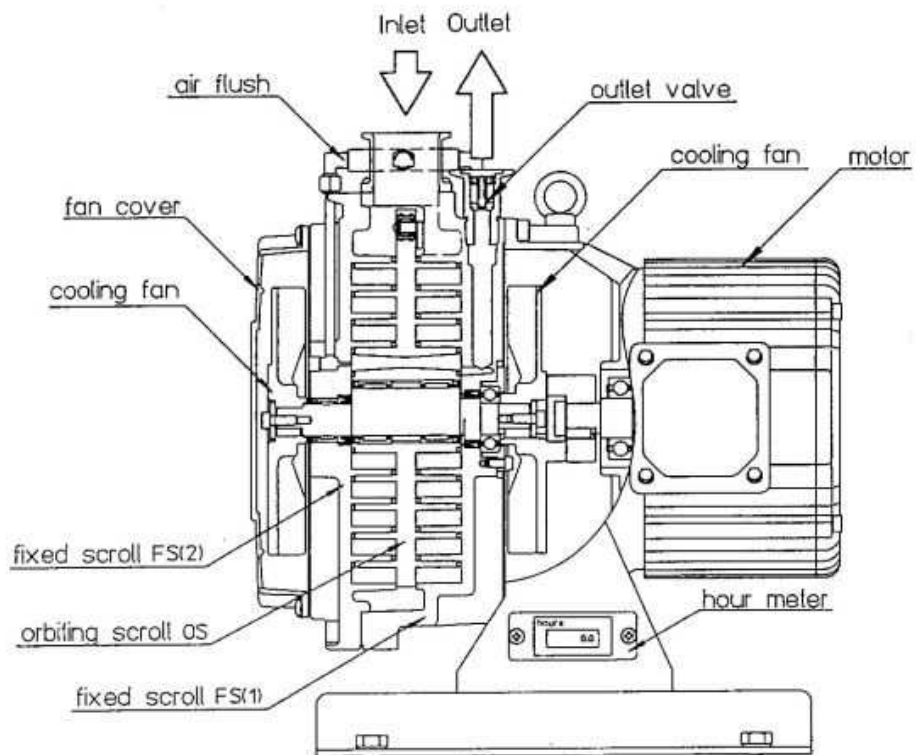

3. 2 I S P - 2 5 0 B

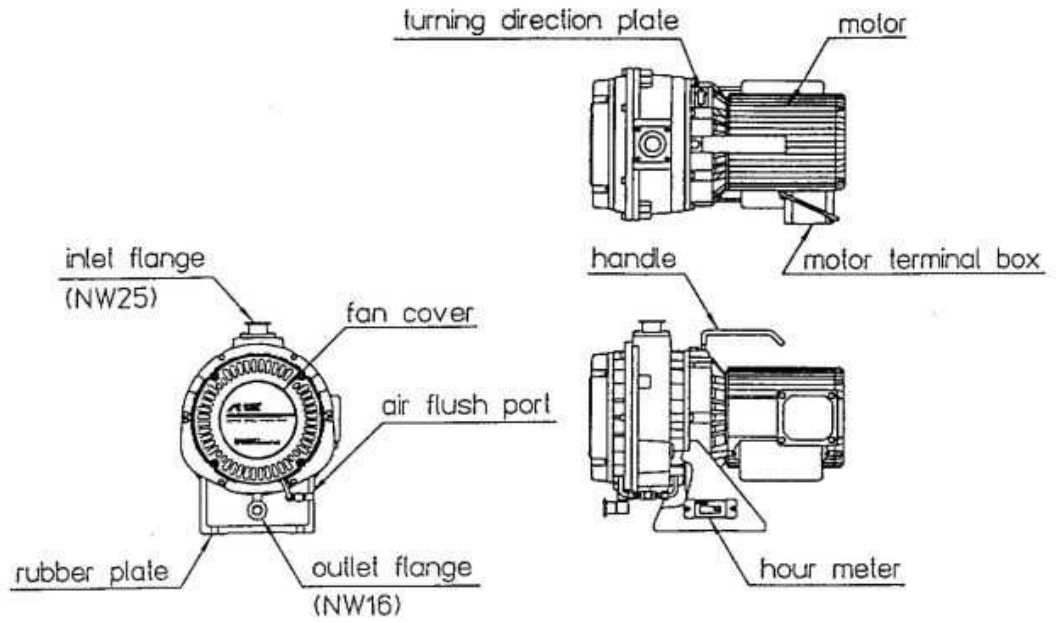

3. 3 I S P - 5 0 0 B

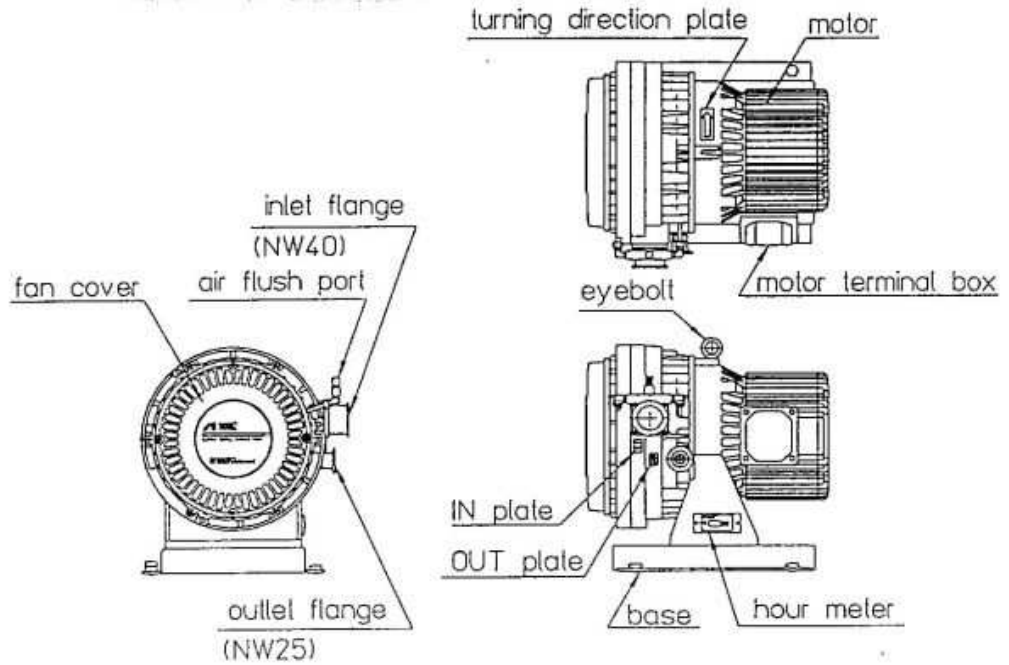

4. Outside dimensions

4. 1 I S P - 2 5 0 B

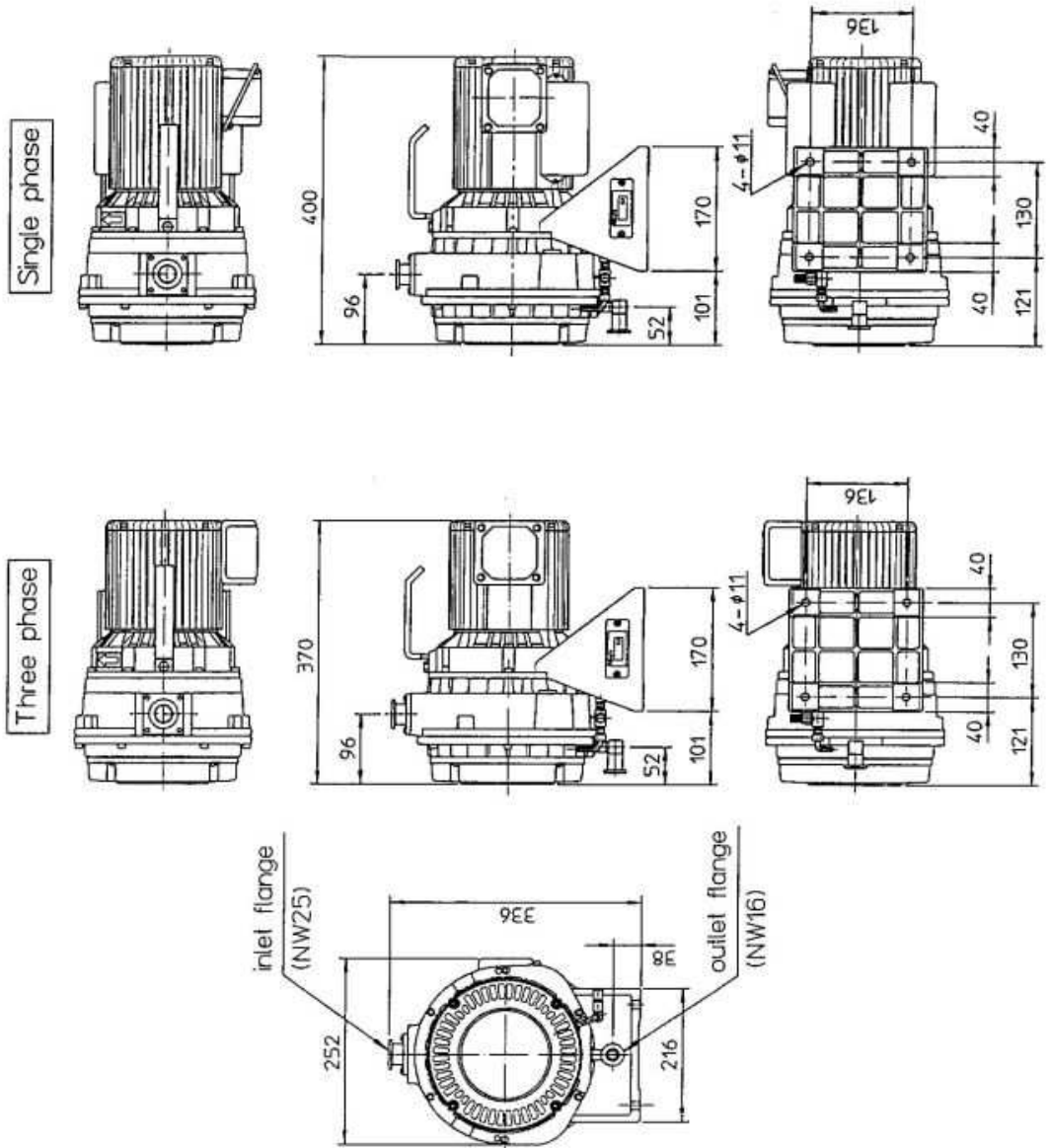

4. 2 I S P - 5 0 0 B

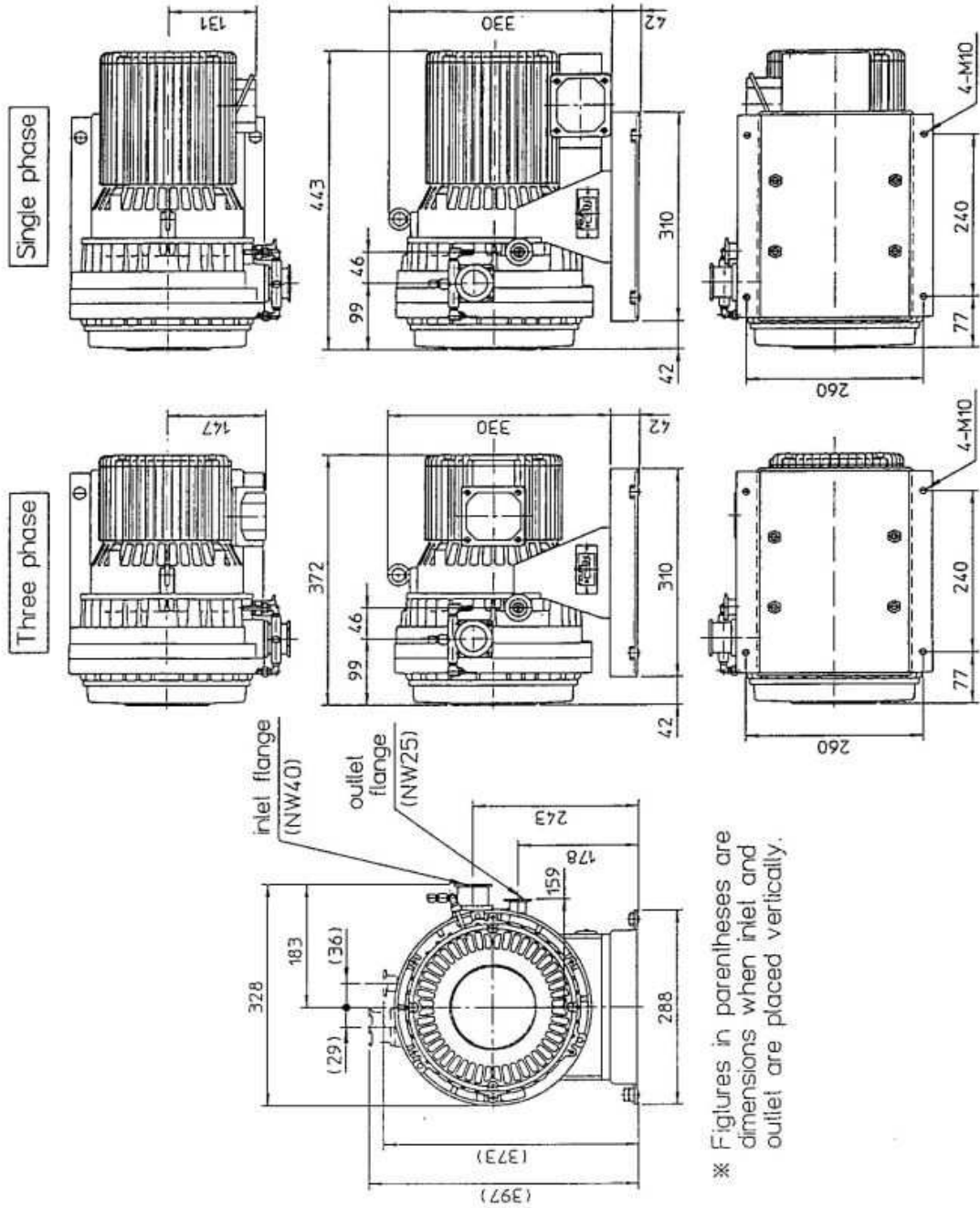

* Figures in parentheses are dimensions when inlet and outlet are placed vertically.

5. Installation

5. 1 Check the product

- Check that the package is right-side-up and then open it.
- Check that model of the product is correct as you ordered.
- Check that there is no damage. If there is any damage, contact the shop which sold it to you.
- Remove inlet blank flange and outlet blank flange. If you continue operation with blank flanges, it can cause damage.
- Check that air muffler for air flush port is in the plastic bag..

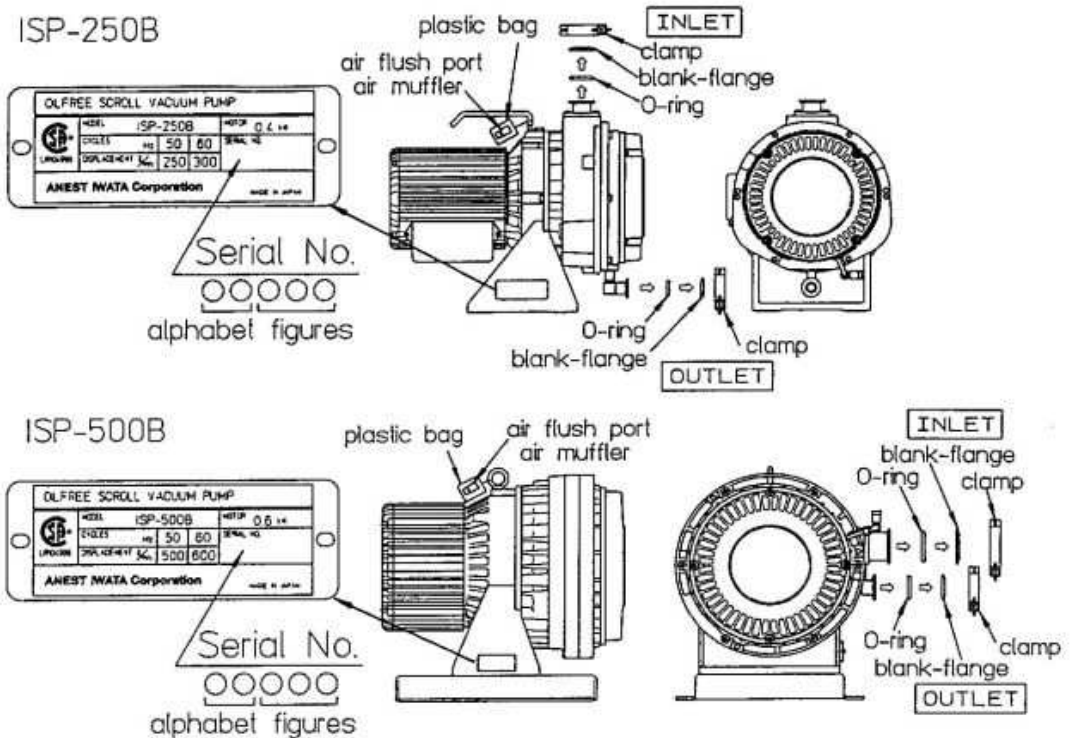

5. 2 Installation

WARNING	
<p>Danger of electric shock Install in an area which is not exposed to moisture such as rain or steam. Moisture on electric source connection can cause bodily injury by short circuit or electric shock.</p>	 Be careful about moisture
<p>Danger of explosion and fire Install in an area which is not exposed to explosives, flammable gas, or other related things. If not, it can cause explosion or fire.</p>	 Be careful about fire



CAUTION

Operate at designated temperature.

Operate at ambient temperature of 5°C~40°C.

Other temperature than designated ones can cause damage, burn or failure.

Pay attention to ventilation.

Install in a well-ventilated area (refer to right chart).

Poor ventilation can cause abnormal overheating, burns or failure since it is air-cooled type.

Install in a safe place.

Install in an area which is not exposed to dust or corrosive gas.

If not, it can cause damage or failure.

Necessary ventilated air	
ISP-250B	ISP-500B
Over 4 m ³ /min	Over 8 m ³ /min



Temperature



Ventilation



Avoid dust

Important

① Install on a firm, level floor.

Be sure to install on a firm, level floor (less than 5° inclination). Uneven installation can cause failure.

If installation floor is unstable, fix pump base by using 4-φ11 holes of pump leg (ISP-250B) or 4-M10 tap screws of pump base (ISP-500B).

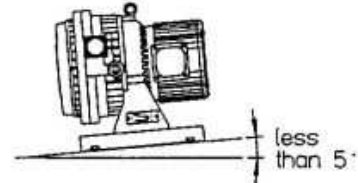

② Install in an area which is not exposed to sunshine.

Direct sunshine can cause high temperature and failure.



Avoid direct sunshine

5. 3 Wiring



WARNING

Ask qualified electrician.

Ask qualified electrician to perform electric wiring job.

If not, electric shock or fire may occur.

Turn off electric source.

Be sure to turn off main electric source on building site.

If not, it can cause injury due to electric shock.



Ask qualified electrician



Turn off electric source

Important

Check electric source and voltage.

Check electric source and voltage before doing the wiring.

There are single-phase and three-phase motors for ISP-500B.

Three-phase has 200V/400V dual voltage. Single-phase has 100V/200V dual voltage.

It is wired to 200V connection when delivered to you.

Check electric source and voltage, and wiring.



Check voltage

How to wire

Remove terminal cover of motor and check terminal block inside.
Wiring diagram is shown inside terminal cover.

• Single-phase specifications

You can change to 100V or 200V connection by changing terminal plate. It is wired to 200V connection when delivered to you.

If you want to change to 100V connection, remove electric source terminal M4 nut and change terminal plate as illustrated below. Connect electric source cord through rubber bushing on the right side of terminal box.

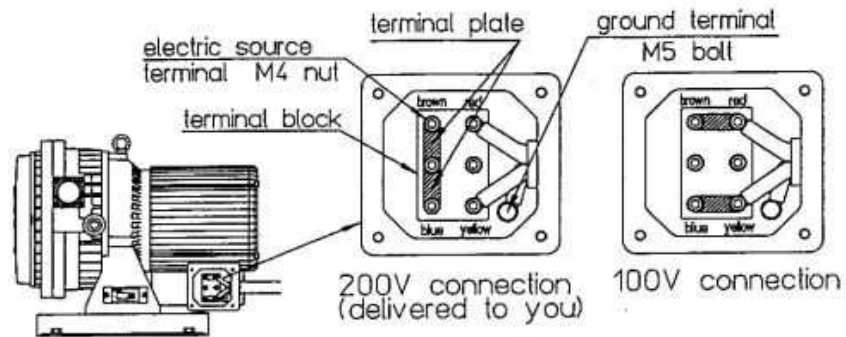

• Three-phase specifications

You can change to 200V or 400V connection by changing terminal plate. It is wired to 200V when delivered to you. If you want to change to 400V connection, remove electric source terminal M4 nut and change terminal plate as illustrated. Connect electric source cord through rubber bushing on the bottom side of terminal box.

Connect R-S-T to U1-V1-W1 terminals of motor, respectively.

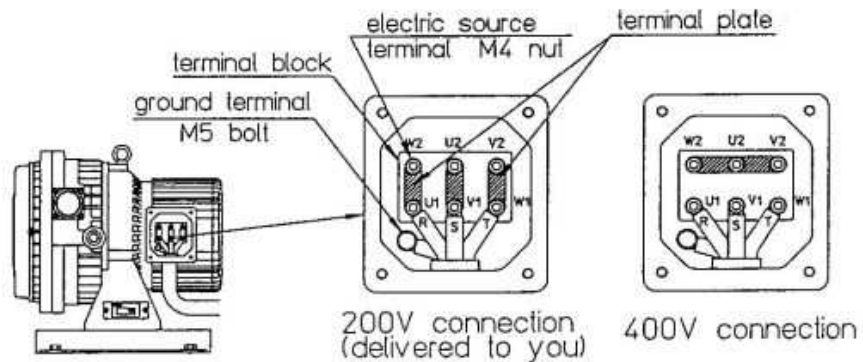

⚠ WARNING

Install emergency stop switch.

Be sure to install electric source switch (or breaker for emergency stop) for emergency stop. If not, it can cause damage or fire.

MOTOR NOT PROTECTED - EXTERNAL OVERHEAT PROTECTION IN ACCORDANCE WITH CE CODE, PART 1, MUST BE PROVIDED.
MOTEUR NON PROTEGE - PROTECTION EXTERIEURE CONTRE LA SURCHARUFFE DOIT ETRE ASSUREE CONFORMEMENT AUCE PREEIERE PARTIE



Install emergency stop switch

Danger of fire due to electricity

- ① Avoid short-circuit by breaker of proper capacity (refer to chart 1)
If not, it can cause bodily injury or fire due to electricity.
- ② Use electric source cord and ground cord of over 2mm² (over rated 7A) for ISP-250B and over 2mm² (over rated 12.5A) for ISP-500B.
If not, it can cause bodily injury or fire due to electricity.
- ③ Firmly fit proper round crimp-style terminal to electric cord with application device and connect to motor terminal. If not, it can cause electrical fire due to looseness or disconnection.
- ④ Be sure to ground.
Connect ground cord to ground terminal in motor terminal box. If not, it can cause bodily injury such as electric shock.

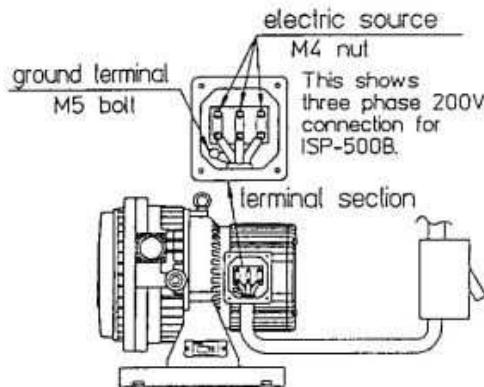

- ⚠ Activate the emergency stop by electric source switch or breaker.
- ⚠ Avoid short circuit by breaker (chart 1).
- ⚠ Use electric source cord and ground cord. { over rated 7.0A for ISP-250B } { over rated 12.5A for ISP-500B }
- ⚠ Use round type terminal. 
- ⚠ Connect ground cord to ground terminal.

Chart-1

Single-phase specifications				Three-phase specifications			
V	Hz	Breaker capacity A		V	Hz	Breaker capacity A	
		ISP-250B	ISP-500B			ISP-250B	ISP-500B
100	50	less than 4.9	less than 9.8	200	50	less than 1.9	less than 3.1
100	60	less than 5.0	less than 11.5	200	60	less than 2.2	less than 3.2
115	60	less than 4.4	less than 9.9	208	60	less than 2.2	less than 3.0
200	50	less than 2.3	less than 4.9	230	60	less than 2.1	less than 2.9
200	60	less than 2.5	less than 5.5	380	50	less than 1.0	less than 1.8
230	50	less than 2.5	less than 4.5	415	50	less than 1.2	less than 1.9
230	60	less than 2.2	less than 4.6	460	60	less than 1.2	less than 1.7

Check turning direction after wiring

Turning direction of pump is clockwise viewed from motor side.

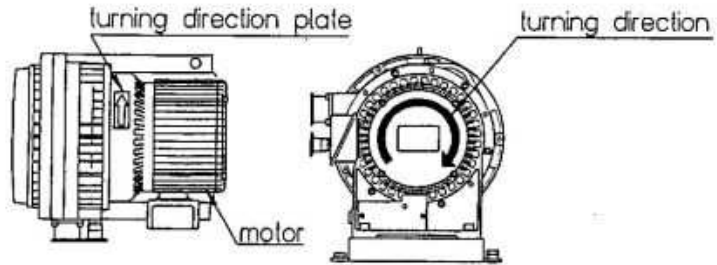

Operate pump with inlet opened, and check that air comes out from outlet. If it turns counterclockwise in case of three-phase, reverse any two phase wires in electric source connection. If you fit pump to vacuum system and switch pump ON-OFF with remote control, first check pump itself about turning direction and then fit it to vacuum system.

Important

Avoid dropping foreign matter inside.

When checking turning directions, avoid dropping foreign matter into inlet. A drop of foreign matter can cause failure.

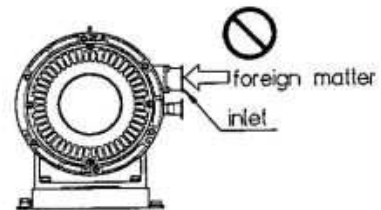

5. 4 Connection to vacuum system (chamber)

- Inlet of ISP-250B is NW25 and outlet is NW16.
- Inlet of ISP-500B is NW40 and outlet is NW25.
- Use isolation valve (we recommend the use of leak valve also) between vacuum chamber and inlet (NW25 for ISP-250B and NW40 for ISP-500B). These valves (isolation valve and leak valve) are used to prevent the drawback of debris attached to the inside of vacuum pump into the vacuum chamber during start-up or shut-down. We recommend the use of automatic valve as isolation valve which closes during power failure in order to prevent the drawback of debris inside pump into the vacuum chamber during power failure.
- Use the clean connecting pipe between vacuum chamber and vacuum pump. We recommend the use of flexible pipe between inlet of pump and vacuum chamber so that vibration of pump does not transmit to vacuum chamber.

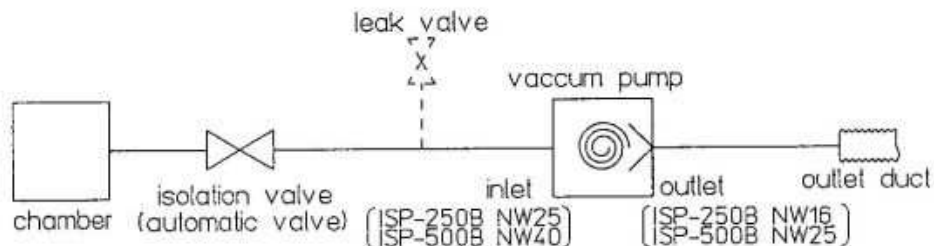

6. Operation

Be sure to use the procedure below to start up or shut down the pump.

Important

If it takes time to reach ultimate pressure of pump during initial operation (also operation after pump has not been used for long time)

Close inlet, and continue operation for 6 ~ 8 hours while opening to atmosphere 2 ~ 3 times per hour.

During pump stoppage, moisture might have entered inside of pump and decreased performance to reach ultimate pressure.

If pump have pumped liquid such as water or high humid air (over 60%RH) during operation

Moisture can deposit in pump and fail pump. Close isolation valve and open inlet to atmosphere several times and exhaust moisture in pump to atmosphere.



CAUTION

Remove blank flanges from inlet and outlet, and operate pump.

Operation with blank flanges fitted can cause damage.

Close isolation valve during start-up or shut-down of pump.

Be sure to close isolation valve between vacuum pump and vacuum chamber during start-up or shut-down of pump. If not, debris attached to the inside of pump can be drawn back to vacuum chamber.

Precautions during restarting of pump

Open inlet to atmosphere before restarting pump.

If not, it can imbalance temperature in pump, resulting in failure.



Close Isolation
valve during
start-up or
shut-down

6. 1 Start-up

- ① Close isolation valve in order to prevent the drawback of debris attached to the inside of vacuum pump into vacuum chamber. (Open leak valve when using leak valve).
- ② Switch vacuum pump on.
- ③ Check start-up of vacuum pump and open isolation valve (close leak valve when using leak valve) and pump the vacuum chamber.

Important

- Continuous pump operation at around ultimate pressure (for example, using as auxiliary pump of turbo molecular pump) can cause deposits of foreign matter or moisture in pump resulting in failure. Do the air flush operation, or close isolation valve and open inlet to atmosphere and operate (once a day for a few minutes) in order to remove foreign matter inside pump.
- Be careful not to damage air flush port (especially air muffler). If not, it can cause damage or accident.
- During air flush operation (ON), noise level becomes a bit higher (by 7 ~ 8dB).
- Install pump in an area which is not exposed to debris such as iron, stone, polishing or wood dust. Debris can clog air mufflers, undercutting air flush effect.

6. 2 Shut-down

- ① In order to prevent the drawback of debris attached to inside of vacuum pump into vacuum chamber during operation, be sure to close isolation valve (open leak valve when using leak valve).
- ② Switch vacuum pump off.
- ③ Open inlet of vacuum pump to atmosphere.

Important

- When pump stops, atmospheric air is drawn back from air flush port to the inside of pump, and pressure inside pump becomes about atmospheric pressure. In order to maintain vacuum in vacuum chamber and prevent the drawback of debris from vacuum pump into vacuum chamber, be sure to close isolation valve to vacuum chamber and stop pump.
- When operating with air flush OFF (closed), operate as per 6.4.

⚠ WARNING

Never pump hazardous gases.

Do not pump hazardous gases to humans, or explosive, flammable, toxic or corrosive gases or substances which contain chemicals, solvents or powders. If done, it can cause bodily injury due to harmful substances, explosion or fire.

! Pump clean gas

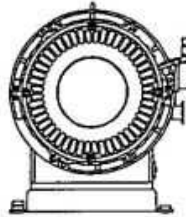

⊘ Do not pump

- Toxic gas
- Explosive gas
- Flammable gas
- Corrosive gas
- Chemicals
- Solvent
- Water
- Powder
- Liquid

Be careful about entanglement.

Never put your fingers or foreign matter into wind holes of fan cover or motor set or clearance between cooling fans of FS(1) and FS(2). If done, it can cause bodily injury such as injury of fingers or foreign matter entering eyes.

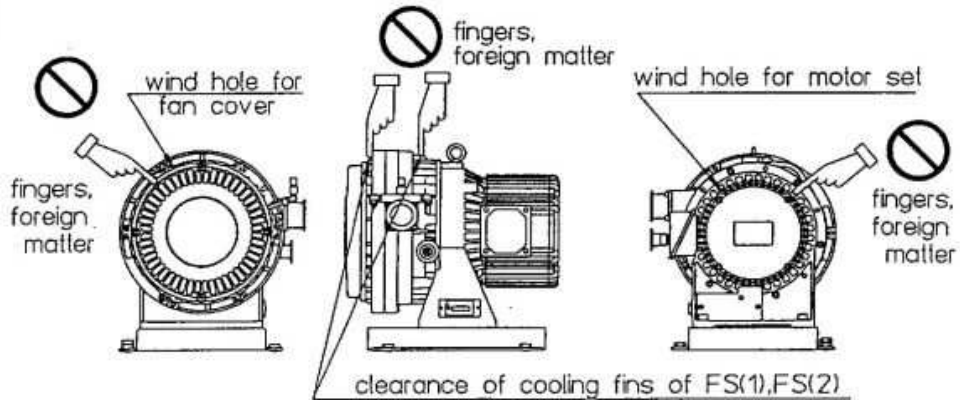

Never alter equipment.

Never remove or alter safety equipment or insulation parts. If done, it can cause electric shock or bodily injury by turning objects.

⊘ Do not operate when fan cover is removed.

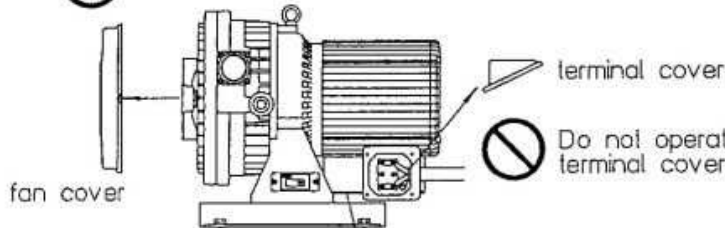

⊘ Do not operate when terminal cover is removed.

⊘ Do not operate when condenser cover is removed (in case of single phase motor)

6. 3 Pumping vapor(air flush operation)

This pump is equipped with air flush port. Before pumping vapor, fully read precautions below and understand the contents.

[Reference] Purpose of air flush

Pumping of humid gas by vacuum pump can cause condensed moisture to remain in pump. This remaining moisture can cause failure to ultimate pressure or pump. Air flush operation is necessary to pump remaining moisture inside. Air flush operation does not only pump moisture but also recovers ultimate pressure.

Important

- Maintenance standard of this pump is based on clean gas pumping. The standard differs when pumping vapor.
- You must shorten maintenance standard (7.1) when pumping vapor since vapor temperature, disposal volume, disposal frequency and substances in vapor have influence on pump operation.
- When pumping vapor, pay attention to the following points.

6. 3. 1 Operation and shut-down

- ① Start pump as per 6.1.
- ② Stop pump as per 6.2.

Important

Operate at designated temperature.

- When pumping vapor, inlet gas temperature must be less than 50°C.
- When vapor temperature is more than 50°C, install a chiller or trap in the piping between vacuum chamber and pump, in order to reduce inlet vapor temperature to less than 50°C.
- Pumping vapor of over 50°C can cause failure.



Pump gas below
50°C
temperature

Operate with air flush port opened.

- When pumping vapor, be sure to open air flush port.
(air flush operation)
- If you pump vapor with air flush port closed, condensed moisture remains in pump, resulting in failure.
- After vapor is pumped, continue air flush operation for over one hour.
- If you close air flush port or stop pump soon after vapor is pumped, condensed moisture remains in pump, resulting in failure.



Operate with
air flush port
opened

ISP-250B

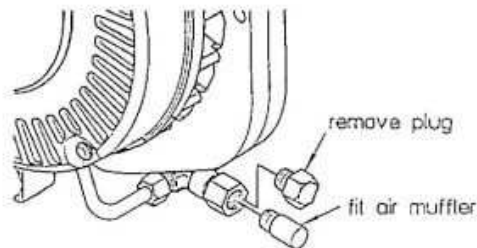

ISP-500B

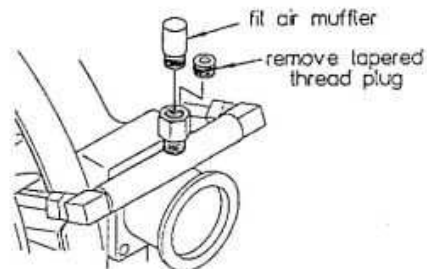

Important

Continuous pumping of humid gas

- When pumping vacuum chamber while humidity in chamber is high, moisture volume drawn into pump differs according to temperature and pressure in chamber.
- When pumping chamber containing gas with humidity of over 60% RH, be sure to open air flush port and operate pump. (air flush operation)



Air flush operation to pump humid gas

6. 4 When finishing air flush operation

When you want to finish air flush operation, first stop pump and then do the following procedure. Never try to do during pump operation.

⚠ WARNING

Never change air flush condition ON-OFF during operation.

Change air flush port condition(ON-OFF)after stopping pump.

Changing air flush condition during operation can fail pump and cause bodily injury.

Never pump vapor

Do not pump vapor when air flush port is OFF(closed).

If done, drawn vapor can condense in pump, failing pump.



Stop pump and then change



Never pump vapor when air flush port is closed

Position of air flush port

ISP-250B

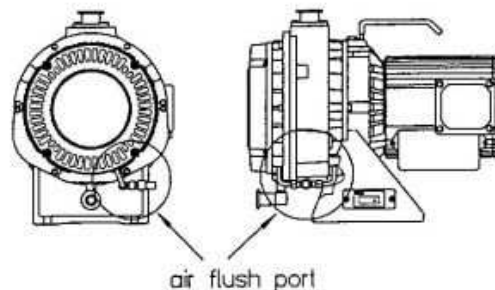

Details of air flush port (viewed from bottom)

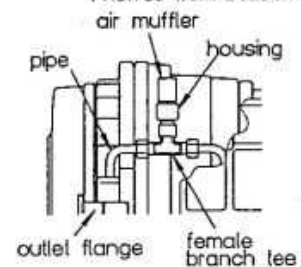

ISP-500B

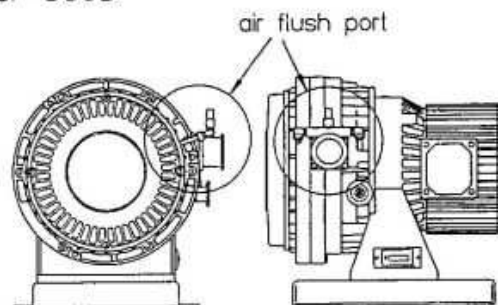

Details of air flush port

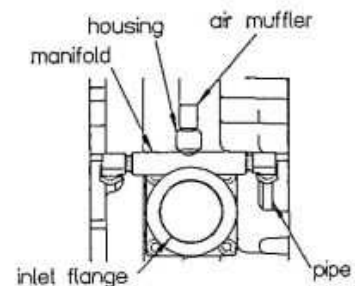

6. 4. 1 Finish air flush operation

To finish air flush operation, remove air muffler of air flush port. As for ISP-250B, lightly tighten plug with spanner. As for ISP-500B, roll peripheral of R1/8 tapered thread plug with sealing tape and screw it into housing of air flush port. Lightly tighten R1/8 tapered thread plug with hex.wrench.

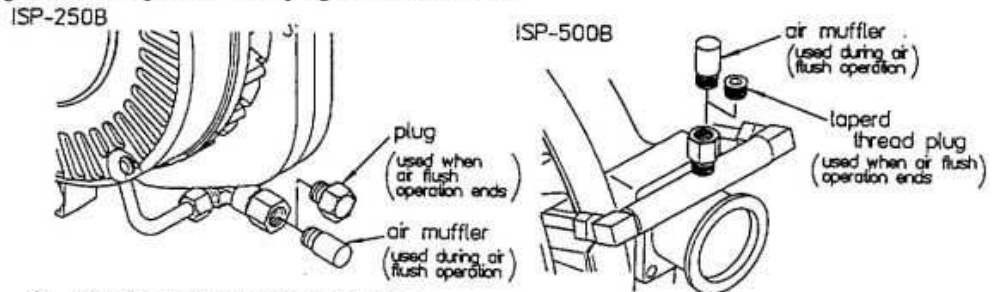

6. 4. 2 Restart air flush operation

To restart air flush operation, remove plug of air flush port and screw it into housing of air flush port.

Important

Remove air muffler, plug and tapered thread plug after stopping pump.
Remove tapered thread plug fully so that the residue of sealing tape does not remain in thread section.

7. Maintenance and inspection

Important

- Neglect of maintenance and inspection can cause poor performance and pump failure.
- In order to remove debris accumulated in vacuum pump, operate pump several times for one minute (once a day) while drawing atmospheric air.



**Observe
maintenance
and inspection**



WARNING

Be careful about high temperature

Do the maintenance after the pump becomes cool enough.
Maintenance soon after shutdown of operation can cause bodily injury such as burns.

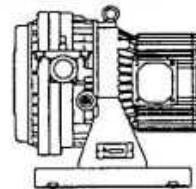

Burn

Switch off electric source

Be sure to switch off electric source before maintenance or inspection.
If not done, it can cause bodily injury such as electric shock or from turning objects.

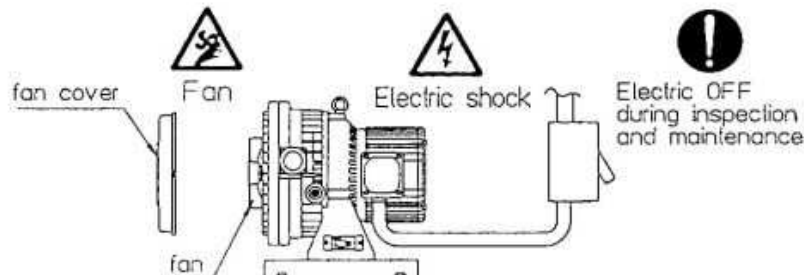

7. 1 Maintenance

When maintenance time has been reached, be sure to contact our distributor who sold it to you. Never disassemble, reassemble or alter on user's side. We are not responsible for any accidents caused by disassembly, assembly or alteration which was done by the user or non-specialist.

Where to inspect	Maintenance time			Remarks	
	yearly or every 8000hr	biennially or every 16000hr	every 400 times vapor pumping		
needle bearing [FS(2)]	grease/△	○	△		
needle bearing [OS]	grease/△	○	△		
ball bearing [FS(1)]	△	○	△		
needle bearing [pin crank]	grease/△	○	△		
O ring [pin crank, needle bearing]	△	○	△		
spider	△	○	△		
seal [pin crank needle bearing]	○	○	△	only ISP-500B	
shaft seal (2) [FS(2)]	○	○	△		
shaft seal (1) [FS(1)]	○	○	△		
G seal [FS(2)]	○	○	△		
G seal [OS]	○	○	△		
G seal [FS(1)]	○	○	△		
outlet valve set	○	○	△		
O ring [outlet flange]	○	○	△		only ISP-250B
O ring [FS(2)]	○	○	△		
O ring [inlet flange]	○	○	△		
tip seal set (1)	△	○	△		
tip seal set (2)	△	○	△		
pin crank set	△	△	△		
air flush kit	○	○	○		

○ · · Replace

△ · · Replace if something goes wrong.

Note : Be sure to use designated ISP exclusive grease.

Important

Causes of failure

Shorten maintenance time if conditions of installation or operation are bad.

Especially ambient temperature has great influence on failure.

Maintenance time is based on 5~40℃ ambient temperature and 25℃ average yearly temperature.

Shorten maintenance time if temperature is over it. If not, it can cause failure.

Maintenance time is not a guarantee time.



**Shorten
maintenance time**

8. Problems and remedies

If something goes wrong, please refer to the following chart and remedy problems. If you cannot solve your problem, please contact our distributor who sold the pump to you or us.

Problems	Causes	Remedies
Pump does not rotate.	Breaker malfunctions.	Inspect and repair.
	Wiring becomes loose or cut.	Repair or replace.
	Voltage drops.	Check length and size of cable.
	Motor malfunctions.	※Inspect and repair.
	Pump malfunctions.	※Inspect and repair.
Ultimate pressure is insufficient.	Air leaks from piping.	Check tightness of piping.
	Moisture and solvent are drawn.	Open inlet to atmosphere and operate for a few minutes and then operate for a time (about 24 hours) while inlet is closed.
	O ring is damaged.	※Replace.
Abnormal sound , vibration	Connection becomes loose.	Tighten connection.
	The set is not level	Make it level.
	Foreign matter enters inside of pump.	※ Inspect and repair.
	Failure of exhaust valve	※ Inspect and repair.
	Failure of motor	※ Inspect and repair.
	Failure of pump	※ Inspect and repair.

※ . . . Contact our distributor who sold it to you.